

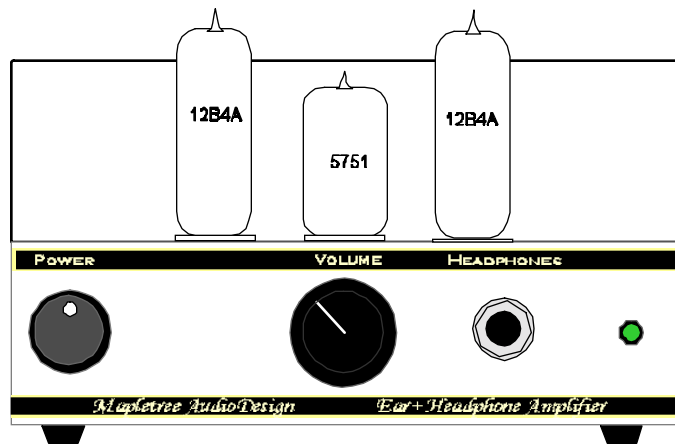

Ear+ Purist Stereo Headphone Amplifier Kit



Assembly and Users' Manual

Rev. July 5/03

Mapletree Audio Design
Lloyd Peppard
R. R. 1, Seeley's Bay, Ontario, Canada, K0H 2N0
(613) 387-3830
MapletreeAD@aol.com
<http://hollowstate.netfirms.com>

© Copyright Lloyd Peppard 2003

Introduction

The Mapletree Audio Design *Ear+ Purist* Stereo Headphone Amplifier kit offers the audiophile kit builder a number of unique features:

- ◆ The exclusive use of high quality new old stock (NOS) and current production tubes that can be obtained at modest cost from many suppliers. The tubes provided are North American and Russian manufactured brand-name types and should exhibit a very long life in this application.
- ◆ Wide frequency response: 10 Hz – 20 kHz –1 dB.
- ◆ A para-feed cathode-follower headphone output circuit capable of driving a wide range of headphones with impedances from 32 to 300 Ohms.
- ◆ DC heater power supply for low noise.
- ◆ A punched, painted chassis with bottom cover plate that provides complete shielding and safety protection.
- ◆ All parts, tubes, hardware, wire, solder, line cord, fuses, and knob are included. Only a few standard tools and a soldering iron are necessary for construction.

Before you Start

Tools required:

- Soldering iron or gun - 40 W min.
- Wire cutters
- Long-nose pliers
- Pocket knife or wire strippers
- Ruler
- Small adjustable wrench
- Philips screwdriver
- Small (1/8") blade screwdriver

Soldering:

- Your soldering iron should be fitted with either a pointed or wedge shaped copper tip that must be kept clean and "tinned" at all times. The tip will pit and oxidize through normal use and proper maintenance is essential. If you are using your iron for the first time, apply solder to the tip as soon as it is hot enough to melt. The shiny "tinned" surface will now protect the tip from oxidation. To keep the tip clean during use, wiping on a wet sponge is recommended. To prepare a pitted or oxidized tip for use, first file or sand the tip to the desired shape, removing all pitted material and oxidation from the surface. Then proceed to tin the tip as described above. Use only electronic grade solder similar to that supplied which is composed of 40% lead and 60% tin. Silver solder, containing a few percent silver is also acceptable.
- Most of the interconnections are made at solder lugs or pins—on a tube socket, terminal strip, switch, or potentiometer. Lugs have openings into which the component leads and wires are inserted. Pins require the wires or component leads to be crimped around the pin with long-nosed pliers. While it is not necessary to wrap the wires tightly around the lugs before soldering, a short right-angle bend at the end of each wire will secure it to the lug until all connections can be soldered permanently in place. When all the wires are in place at a particular lug or pin, the instruction to apply solder will be stated as [S(*n*)] where *n* is the number of wires and component leads which should be terminated at that point. If the number does not agree with what you see, then you should go back and correct your work before proceeding. When you are ready to make a soldered connection, place the tip of your iron against the lug or pin to heat it and the terminating wires so that solder will melt against them. *Note that solder is applied to the lug and wires, not to the solder tip.* You may however find that the transfer of heat from the tip to the joint is enhanced if a small amount of solder is melted on the tip before applying it to the joint.
- An alternate technique for soldering connections, especially when excessive heat applied to a component is to be avoided (e.g. a rectifier bridge or diode), is to pre-tin the component lead by applying the tip of the iron to the end of the lead and quickly melting a small amount of solder on the wire. The lead should be held by long-nose pliers, which act as a heat sink. A solder lug can also be pre-tinned by applying

enough solder to completely fill the hole. Then the pre-tinned lead(s), held by long-nose pliers, is inserted into the lug as the solder is re-melted by application of the iron tip.

- A properly soldered connection should be smooth and shiny. Solder should fill all openings in the lugs, visibly adhering to each wire. Dull looking joints ("cold joints") should be re-heated, a small amount of fresh solder applied, and let cool without any movement of the wires involved. If you are new to soldering, screw the extra lug terminal strip supplied to a board and practice with some spare wire until you are satisfied with your technique. The photo below shows a properly soldered lug connection.

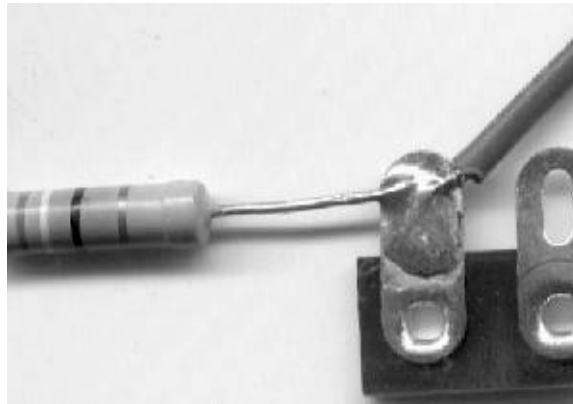

Wire:

- The wire supplied is 20 gauge stranded tinned copper or solid copper. The wire colors supplied and specified in the instructions make it easier to check your work and to troubleshoot should problems arise later.
- Wire preparation involves cutting to length and stripping the insulation from each end. The lengths of wires are given in the instructions. Unless otherwise stated, the ends of each wire should be stripped to expose 1/4" or slightly less of bare wire using a small pocketknife or wire strippers. This allows for a 1/8" bend in the wire to permit attachment to a solder lug or to crimp around a pin.

Preparation:

- A clear, clean, well-lit work surface is essential for kit assembly. An adjustable lamp that can be brought close to the work when necessary is a real advantage. You will need access to an electrical outlet for your soldering iron.
- The chassis has been carefully primed, painted, and baked but the surface can still be damaged by abrasion during assembly. This can be avoided by placing a clean towel or similar covering on the work surface. The chassis will be placed upside down for most of the assembly.

- Layout all the parts and make sure you can identify each one by making an inventory against the parts list at the end of this manual or the packing list enclosed with the kit. During assembly, verify the values of the resistors using the color codes given in the instructions.
- The assembly will proceed in several phases, each of which represents a reasonable amount of work for one session. For clarity, the wiring diagrams show only the components and connections relevant to a particular phase. The schematic diagram for the complete circuit is shown at the end of this manual. While it is useful in describing the overall circuit and in identifying the voltages at various points in the circuit, unless you are very experienced, you should assemble the kit following the wiring diagrams rather than the schematic, although they are electrically equivalent. The layout and wiring schemes are designed to yield not only a properly functioning unit but a visually satisfying result as well. It is important to enjoy the assembly process—so take your time!

Phase 1: Mechanical Assembly

In referring to the instructions and wiring diagrams, unless otherwise stated, it is assumed that the chassis is oriented on your work surface (protected by a towel as suggested above) upside down, with the front panel (narrow side) toward you. You should check off each of the following steps as you complete them. Refer to Wiring Diagrams 1 and 2.

1. Mount the three 9-pin tube sockets with their mounting flanges on the inside of the chassis as shown in Wiring Diagram 2 using 4-40 3/8" machine screws and hex nuts. Orient the sockets so the gap in the lugs faces the front of the chassis as shown. Bend the lugs outward with your finger to facilitate access for soldering connections.
2. Mount the fuse holder on the rear panel with the lugs oriented as shown in Wiring Diagram 2. The white washer goes under the hex nut on the inside. If you find that there is not enough room to use a wrench, tighten the nut as securely as possible by hand, and then twist the fuse holder from the outside. It will tighten quite easily as the white washer compresses. Make sure the side lug is still accessible after tightening.
3. Mount the 2 RCA jacks (J1a,b) on the rear panel with the ground lugs under the hex nuts. Use a small adjustable wrench, pliers, or a small socket wrench to tighten the hex nuts. Bend the ground lugs away from the chassis by slipping a knife blade under the lugs.
4. Mount the IEC ac receptacle (J4) on the rear panel with two 6-32 3/8" machine screws and hex nuts. Orient the receptacle so the center lug is closest to the open side of the chassis.
5. Mount power transformer TR1 on the top side of the chassis, with the pins pointing up, with two 8-32 1" machine screws threaded into the holes near the corners of the transformer from underneath the chassis. Terminal strip T1 is fastened under the screw nearest the center of the chassis as shown. Make sure the transformer pin numbers are oriented as shown.
6. Mount power transformer TR2 on the top side of the chassis with the pins pointing up with two 8-32 1" machine screws threaded into the holes near the edges of the transformer from underneath the chassis. Bridge rectifier BR1 is fastened under the screw nearest the side of the chassis as shown with its flat corner positioned toward the side of the chassis. Make sure the transformer pin numbers are oriented as shown.
7. Trim off the leads of BR1 to about 1/2".
8. Attach the 4-lug terminal strips T2 and T3 in the locations shown with 6-32 3/8" machine screws and hex nuts.
9. Mount ac power switch SW1 in the position shown by snapping it in place from the front side of the panel oriented with the white dot nearest the top of the

chassis.

10. Locate the green light emitting diode (LED) D5 and the holder and retaining ring. Refer to the photo below to identify the three pieces.



11. Push the holder through the hole in the front panel so it snaps in place. Push the LED into the holder from inside the chassis. It should fit firmly in place. You may have to push on the back of the LED with a small screwdriver. Orient the long lead of the LED toward the outside of the chassis as shown. Slip the retaining ring over the rear of the LED assembly and push tightly against the chassis.
12. Locate the volume control potentiometer P1 (dual 100K). Mount it in the front panel in the position shown with the lugs oriented toward you. Use the flat washer under the hex nut. Tighten with a small adjustable wrench.
13. Plug in your soldering iron. Locate the stereo headphones jack J2. The single lug near the front is the ground (G) connection. The two lugs on the rear are the left (L) and right (R) connections. Prepare (“prepare” means to cut to length and strip ¼" or a bit less from each end) a 3" black wire and connect one end to the ground lug of J2 [S(1)].
14. Prepare a 3½" red wire and connect one end to the R lug of J2 [S(1)].
15. Prepare a 3" green wire and connect one end to the L lug of J2 [S(1)].
16. Mount J2 so the ground lug is toward the open side of the chassis as shown in diagram 2. Use the flat washer under the hex nut and tighten with an adjustable wrench.

💡 **“Pre-tinning” wires/leads:** One technique you may want to try as an aid to making good solder connections is to heat the end of a wire or lead with your iron and apply a small amount of solder to it beforehand. After it is inserted into a lug, the application of your iron and a bit more solder will quickly complete the connection. It takes less heat to re-melt the solder than to heat the wire itself.

This completes Phase 1. Check your work against the wiring diagrams, paying particular attention to the orientation of the tube sockets, the rectifier bridge BR1, and transformers TR1 and TR2.

Phase 2: Power Supply and Input/Output Wiring

For the following steps, refer to Wiring Diagrams 1 and 2.

 **Connecting wires to transformer and similar pins:** Make a hook in the stripped end of the wire and slip it over the pin. Crimp it around the pin with your long-nose pliers to make a secure connection until you are ready to apply solder.

1. Connect a short length of bare wire between pins 2 and 4 of transformer TR1.
2. Prepare a 2" length of black wire. Connect one end to pin 1 of TR1 and the other end to pin 3 of TR1.
3. Prepare a 1½" length of red wire. Connect one end to pin 6 of TR1 [S(1)] and the other end to pin 7 of TR1 [S(1)]
4. Locate the four FR107 diodes and take note of the band around one end. The diodes must be oriented properly using this band which indicates the polarity (the banded end is the cathode). The diodes are designated D1-D4 in the wiring diagram corresponding to the schematic diagram.

 **Soldering diode leads:** When soldering the diodes, it is important to limit the heat transferred to the diode from the soldering iron. You should grip the lead near the diode body with long-nose pliers during soldering to act as a heat sink. When two leads are involved, you can grip both with your pliers or use a hemostat (available at a drugstore) clamped on the leads.

5. Trim both leads of all four diodes to ¾".
6. Make a small loop in the lead from the *banded* end of one diode (D4) and slip it over pin 5 of TR1. Make a small loop in *unbanded* end of one diode (D1) and slip it over pin 5 of TR1 [S(2)].
7. Make a small loop in the lead from the *banded* end of one diode (D3) and slip it over pin 8 of TR1. Make a small loop in *unbanded* end of the last diode (D2) and slip it over pin 8 of TR1 [S(2)].
8. Slip ½" of insulation tubing over the *unbanded leads* of diodes D3 and D4, leaving about ¼" of lead exposed at the ends. Twist the bare ends together with your long-nose pliers and solder the connection.
9. Prepare a 4½" length of black wire. Pre-tin one end of this wire and solder to the twisted ends of diodes D3 and D4 by re-melting the joint with your iron. Slip a ¾" length of heat shrink tubing over the black wire and push it over the soldered connection you have just made. Apply heat with your soldering iron or a match near the heat shrink tubing so it contracts over the connection. Push the black wire

through the hole nearest the front of the chassis.

10. Slip ½" of insulation tubing over each of the *banded* leads of D1 and D2 and twist the bare ends together with your long-nose pliers and solder the connection.
11. Prepare a 4" length of red wire. Pre-tin one end of this wire and solder to the twisted ends of diodes D1 and D2 by re-melting the joint with your iron. Slip a ¾" length of heat shrink tubing over the red wire and push it over the soldered connection you have just made. Apply heat with your soldering iron or a match near the heat shrink tubing so it contracts over the connection. Push the red wire through the hole nearest the rear of the chassis.
12. Connect a short length of bare wire between pins 6 and 7 of TR2. Solder both connections.
13. Prepare a 1½" length of black wire and connect from pin 1 of TR2 to pin 3 of TR2 [S(1)].
14. Prepare a 1½" length of black wire and connect from pin 2 of TR2 [S(1)] to pin 4 of TR2.
15. Prepare a 1½" length of black wire and connect from pin 4 of TR2 [S(2)] to pin 3 of TR1 [S(2)].
16. Prepare a 1½" length of black wire and connect from pin 1 of TR2 [S(2)] to pin 4 of TR1 [S(2)].
17. Prepare a 3½" length of black wire and connect from pin 2 of TR1 [S(2)], through the hole nearest the rear of the chassis, to lug 1 of ac jack J4 [S(1)].
18. Prepare a 6" length of green wire and connect from pin 5 of TR2 [S(1)], through the hole nearest the rear of the chassis, to pin 2 of rectifier bridge BR1 [S(1)].
19. Locate resistor R8 (1.8 Ohms (1R8) 5% 5W) and trim each lead to ¾". Make a loop at the end of one lead with your long-nose pliers and connect to pin 8 of TR2 [S(1)]. The resistor body is positioned on end against the side of TR2 as shown. Bend the bottom lead of R8 at right angles and make a loop at the end. There should be at least ¼" clearance from the metal of the chassis.
20. Prepare a 5" length of green wire and connect to the bottom lead of R8 [S]. Slip a ¾" of heat shrink tubing over the solder joint and heat with your soldering iron or a match. Feed the free end of the wire through the hole nearest the front of the chassis and connect to pin 4 of rectifier bridge BR1 [S(1)].
21. Prepare a 4" length of green wire. Connect one end to the solder lug of RCA jack J1a [S(1)] and the other end to lug 3 of the ac receptacle J4 [S(1)].

22. Prepare a 1½" black wire. Connect one end to lug 2 of J4 [S(1)] and the other end to lug 1 of the fuse holder FU1 [S(1)].
23. Locate the twisted pair of black wires. At the end with the wires the same length, connect one end to each lug of SW1 (which lug to which wire is not important). Solder the connections at both lugs.
24. Run the twisted pair of black wires down the side of the chassis and connect the shorter wire to lug 2 of fuse holder FU1 [S(1)]. Feed the longer wire through the hole nearest the rear of the chassis and connect to pin 1 of TR1 [S(2)].
25. Attach the transformer cover box to the top of the chassis using two #6 sheet metal screws from the under side of the chassis. Turn the chassis upside down for the remaining steps.
26. Connect the red wire coming from the hole nearest the rear of the chassis to connect to lug 1 of terminal strip T1.
27. Locate capacitor C5 (47uF/350V) and identify the negative lead denoted by the black band around the body of the capacitor. Connect this *banded* lead to lug 4 of T1. Connect the other end of C5 to lug 1 of T1.
28. Locate resistor R5 (2.7K (2K7) 5% 5W). Trim the leads as necessary and connect between lugs 1 [S(3)] and 3 of T1.

 **Reading resistor color codes:** The value of a resistor is usually indicated by a series of color bands which give not only the value in Ohms but the % precision, and sometimes the temperature characteristics. For the small resistors in you kit, which are rated at 0.6 W, the precision varies from 1% to 0.1%, depending on the stock on hand. For simplicity, they are all referred to as 1% in the instructions. Only the four color bands needed to read the actual value are given in the instructions. If you look closely at one of these resistors, you can see that one of the end bands is slightly wider than the other. The value is read from the end with the narrower band. For the larger resistors (1W and 2W, 5%), the color code consists of three color bands plus a gold 5% precision band. For 5 W resistors, the value is labeled on the resistor body. For information on reading the code, see the Appendix of this manual.

29. Locate resistor R6 (4.7K 1% 0.6W: yellow-violet-black-brown). Trim the leads as necessary and connect one lead to lug 3 of T1 and the other lead to lug 2 of T1.
30. Locate capacitor C7 (47uF/250V) and identify the negative lead denoted by the light color stripe running down one side of the capacitor. Slip insulation tubing over both leads leaving about ¼" exposed. Connect the negative (striped) lead to lug 4 of T1 and the other lead to lug 2 of T1.
31. Locate capacitor C6 (47uF/250V) and identify the negative lead denoted by the light color stripe running down one side of the capacitor. Trim the leads as necessary and connect the negative (striped) lead to lug 4 of T1 [S(3)]. Connect

the other lead of C6 to lug 3 of T1.

32. Prepare a 6½" red wire. Connect one end to lug 2 of T1 [S(3)] and the other end to lug 2 of T3.
33. Prepare a 5" red wire. Connect one end to lug 3 of T1 [S(4)] and the other end to lug 9 of V3.

This completes wiring to terminal strip T1. Check that each lug has the following number of leads/wires attached and soldered securely:

Lug 1 – 3
Lug 2 – 3
Lug 3 – 4
Lug 4 – 3

34. Locate the pre-formed copper ground bus wire. Solder one to lug 4 of T1 by re-melting the previously made solder joint and applying more solder to make a secure connection. Connect the other end to the center post of tube socket V1 [(S)]. The ground bus is used to make multiple connections to the circuit ground node.
35. Connect the black wire coming through the hole nearest the front of the chassis to the ground bus [S].
36. Prepare a 3" red wire. Connect one end to lug 9 of V3 [S(2)] and the other end to lug 9 of V2 [S(1)].
37. Locate capacitor C8 (4700 uF/16V) and note the negative lead denoted by the black stripe down one side of the capacitor. Trim the leads as necessary, slip insulation tubing over both leads, and connect the negative (striped) lead to pin 1 of rectifier bridge BR1. Connect the other lead to pin 3 of BR1.
38. Prepare a 4" length of green wire and connect from pin 3 of BR1 [S(2)] to lug 4 of tube socket V2.
39. Prepare a 4" length of black wire and connect between pin 1 of BR1 [S(2)] and lug 5 of tube socket V2.
40. Prepare a 3" length of green wire. Connect one end to lug 4 of V2 [S(2)] and the other end to lug 4 of V3.
41. Prepare a 3" length of black wire. Connect one end to lug 5 of V2 [S(2)] and the other end to lug 5 of V3.
42. Prepare a 3½" length of green wire. Connect one end to lug 4 of V3 and the other end to lug 4 of V1 [S(1)].

43. Prepare a 3½" length of black wire. Connect one end to lug 5 of V3 and the other end to lug 5 of V1 [S(1)].
44. Connect a short length of bare wire from lug 9 of V1 [S(1)] to the ground bus [S].
45. Locate resistor R7 (1K 1W 5%: brown-black-red-gold). Trim the leads as necessary and connect one lead to lug 4 of V3 [S(3)] and the other lead to lug 1 of terminal strip T2.
46. Trim ½" from each lead of the LED pilot light D1. Form a loop at the end of each lead with long-nose pliers.
47. Prepare a 7" length of green wire. Connect one end to lug 1 of T2 [S(2)] and the other end to the loop in the long lead of LED D5 [S]. When soldering to D5, grip the lead near the LED body with long-nose pliers to protect the LED from excessive heat.
48. Prepare a 6" length of black wire. Connect one end to lug 5 of V3 [S(3)] and the other end to the loop in the short lead of LED D5 [S]. When soldering to D5, grip the lead near the LED body with long-nose pliers to protect the LED from excessive heat.
49. Connect a short length of bare wire between lug 6 [S(1)] and lug 3 of volume control potentiometer P1.
50. Prepare a 2" black wire. Connect one end to lug 3 of P1 [S(2)]. The free end will be connected to the ground bus later.
51. Prepare a 12" red wire. Connect one end to the center lug of jack J1b [S(1)] and the other end to lug 1 of potentiometer P1 [S(1)].
52. Prepare a 12" green wire. Connect one end to the center lug of jack J1a [S(1)] and the other end to lug 4 of P1 [S(1)].
53. Prepare a 14" length of black wire. Connect one end to the ground lug of J1b [S(1)]. Spiral wrap this black wire around the red and green wires running down the edge of the chassis from the RCA jacks. Leave about ¾" between wraps. The free end will be connected to the ground bus later.

This completes Phase 2. Double check all wiring against the wiring diagrams and inspect each solder joint to ensure it is shiny and clean with solder adhering to each wire/lead.

Phase 3: Amplifier Circuit Wiring

For the following steps, refer to Wiring Diagram 3.

1. Prepare a 3½" length of red wire. Connect one end to lug 6 of V1 [S(1)] and the other end to lug 2 of V3 [S(2)].
2. Prepare a 4½" length of green wire. Connect one end to lug 1 of V1 [S(1)] and the other end to lug 2 of V2 [S(2)].
3. Locate resistors R1a and R1b (330K 1% 0.6W: orange-orange-black-orange). Trim one lead of R1a to ¾" and connect to lug 2 of V1. Connect the other lead to the ground bus [S].
4. Trim one lead of R1b to ¾" and connect to lug 7 of V1. Connect the other lead to the ground bus [S].
5. Locate resistors R2a and R2b (1K 1% 0.6W: brown-black-black-brown). Trim one lead of R2a to ¾" and connect to lug 3 of V1. Connect the other lead to the ground bus [S].
6. Trim one lead of R2b to ¾" and connect to lug 8 of V1. Connect the other lead to the ground bus [S].
7. Locate capacitors C1a and C1b (1uF 250V polypropylene). Trim one lead of C1a to ¾". Connect this lead to lug 2 of V1 [S(2)]. Trim the other lead as necessary, slip insulation tubing over the lead, and connect to lug 5 of P1 [S(1)].
8. Trim one lead of C1b to ¾". Connect this lead to lug 7 of V1 [S(2)]. Trim the other lead as necessary, slip insulation tubing over the lead, and connect to lug 2 of P1 [S(1)].
9. Locate capacitor C2a (47uF/25V). Note the stripe running down the side which denotes the negative lead. The other lead is the longer of the two and is the positive lead. Connect the positive lead to lug 3 of V1 [S(2)]. Connect the negative lead to the ground bus [S].
10. Locate capacitor C2b (47uF/25V). Connect the positive lead to lug 8 of V1 [S(2)]. Connect the negative lead to the ground bus [S].
11. Locate resistors R3a and R3b (100K 1% 0.6W: brown-black-black-orange). Trim the leads of R3a as necessary and slip insulation tubing over both leads. Connect one lead to lug 2 of V2 and the other lead to lug 2 of T3.
12. Trim the leads of R3b as necessary and slip insulation tubing over both leads. Connect one lead to lug 2 of V3 and the other lead to lug 2 of T3 [S(3)].

13. Connect the free end of the black wire previously connected to the ground lug of the headphones jack J2 to the ground bus [S].
14. Connect the free end of the black wire previously soldered to lug 3 of P1 to the ground bus [S].
15. Connect the free end of the black wire spiral-wrapped around the red and green wires from the input jacks to the ground bus [S].

For the following steps, refer to Wiring Diagram 4.

16. Locate the two output transformers TR3a and TR3b. These will just fit in the space provided so take care in their installation. Note that one of the black leads is marked with green masking tape.
17. Mount transformer TR3a in the position shown using two 6-32 3/8" machine screws/hex nuts. You will need to use your long-nose pliers to hold the nut near the front of the chassis as you start the screw. Make sure the transformer body does not short against the R lug of J2.

 **Attaching hex nuts to “almost inaccessible” machine screws:** Fold a small length of masking tape to form a double sided pad. Stick one side to the tip of your finger and the other to the hex nut. You can now reach the end of the machine screw without dropping the nut. Start threading the nut with a screwdriver from the other side.

18. Mount transformer TR3b in the same manner.
19. Prepare a 2" length of red wire. Connect one end to lug 2 of T2 and the other end to lug 1 of V3 [S(1)].
20. Locate capacitor C3b (33uF/160V) and identify the negative lead denoted by the stripe running down the side of the capacitor. Trim the leads as necessary and connect the negative lead to lug 3 of T2. Connect the other (positive) lead to lug 2 of T2.
21. Locate capacitor C4b (1uF/250V). Trim the leads as necessary and connect one lead to lug 3 of T2 and the other lead to lug 2 of T2.
22. Trim the black leads from transformer TR3b as necessary, referring to the wiring diagram. Connect the black lead with the masking tape tag to the ground bus as shown [S]. Connect the other black lead to lug 3 of T2 [S(3)].
23. Locate resistor R4b (7.5K 3W). Trim the leads as necessary and connect one lead to lug 2 of T2 [S(4)]. Connect the other lead to the ground bus [S].
24. Prepare a 1½" length of green wire. Connect between lug 1 of V2 [S(1)] and lug 3 of terminal strip T3.

25. Locate capacitor C3a (33uF/160V) and identify the negative lead denoted by the stripe running down the side of the capacitor. Trim the leads as necessary and connect the negative lead to lug 1 of T3. Connect the other (positive) lead to lug 3 of T3.
26. Locate capacitor C4a (1uF/250V). Trim the leads as necessary and connect one lead to lug 1 of T3 and the other lead to lug 3 of T3.
27. Trim the black leads from transformer TR3a as necessary, referring to the wiring diagram. Connect the black lead with the masking tape tag to the ground bus as shown [S]. Connect the other black lead to lug 1 of T3 [S(3)].
28. Locate resistor R4a (7.5K 3W). Trim the leads as necessary and connect one lead to lug 3 of T3 [S(4)]. Connect the other lead to the ground bus [S].
29. Prepare a 2½" length of black wire. Connect one end to the 0Ω lug of TR3a [S(1)] and the other end to the 0Ω lug of TR3b.
30. Prepare a 1½" black wire. Connect one end to the 0Ω lug of TR3b [S(2)] and the other end to the ground bus [S].
31. Connect the free end of the green wire previously soldered to the L lug of J2 to the 8Ω lug of TR3a [S(1)].
32. Connect the free end of the red wire previously soldered to the R lug of J2 to the 8Ω lug of TR3b [S(1)].

This completes the wiring of your *Ear+*. Check all connections against the wiring diagrams, looking for dull (“cold”) solder joints or shorts between wires on adjacent lugs. Solder joints can be reheated with the application of a little fresh solder to correct any problems. Install the knob on the shaft of potentiometer P1 using a small blade screwdriver to tighten the setscrew.

Phase 4 - Checkout

1. Insert one of the ½ A fuses in the fuse holder FU1.
2. Insert the three vacuum tubes in their correct sockets (refer to drawing below).
3. Connect the ac line cord to the ac receptacle.
4. If you have access to a multimeter, you should carefully turn the chassis upside down and clip the black meter lead to the ground bus. Clip the red lead to lug 1 of terminal strip T1. Set your meter to read dc Volts on a scale of 300 V or greater.
5. Plug in the ac line cord.
6. Turn on the power switch. The green pilot lamp should come on.
7. If you have connected a meter, the dc voltage at lug 1 of T1 should settle at about +300 VDC. Other voltages are shown on the schematic diagram.
8. Check that the heaters of all the tubes are glowing with a dull orange color. The heater voltage can be measured between pins 4 and 5 of any of the tubes and should be close to 12 VDC.
9. Check for any unusual odors that might indicate an overheated component.
10. Leave the amplifier on for a few minutes until you are satisfied that it is in a stable condition.
11. Turn the amplifier off and unplug the line cord.
12. Attach the bottom plate using four 6-32 sheet metal screws. Apply the four stick-on feet to the corners of the bottom plate.
13. You are now ready to test the signal portion of your amplifier.
14. Connect both channels of the source (e.g. CD player output) to the input jacks—J1a (left) and J1b (right). Plug in your headphones to the headphones jack on the front panel. Adjust the volume control fully counter-clockwise (CCW). Turn the amplifier on. You should not hear any noise in the headphones once the tubes have warmed up (about 30 sec).
15. With a source signal present, turn up the volume and verify that there is a stereo signal present in your headphones.

This completes the formal checkout procedure.

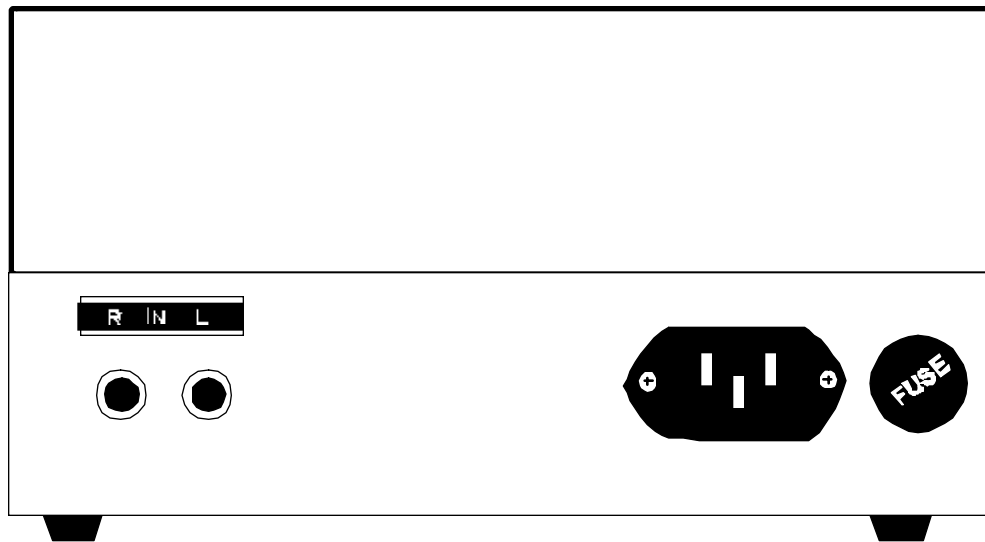
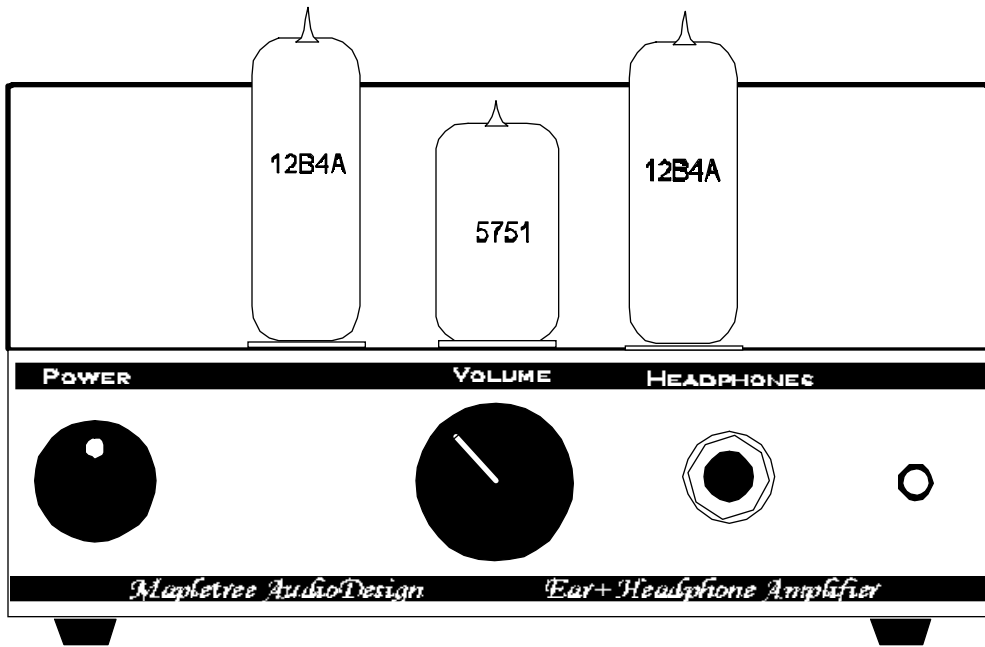

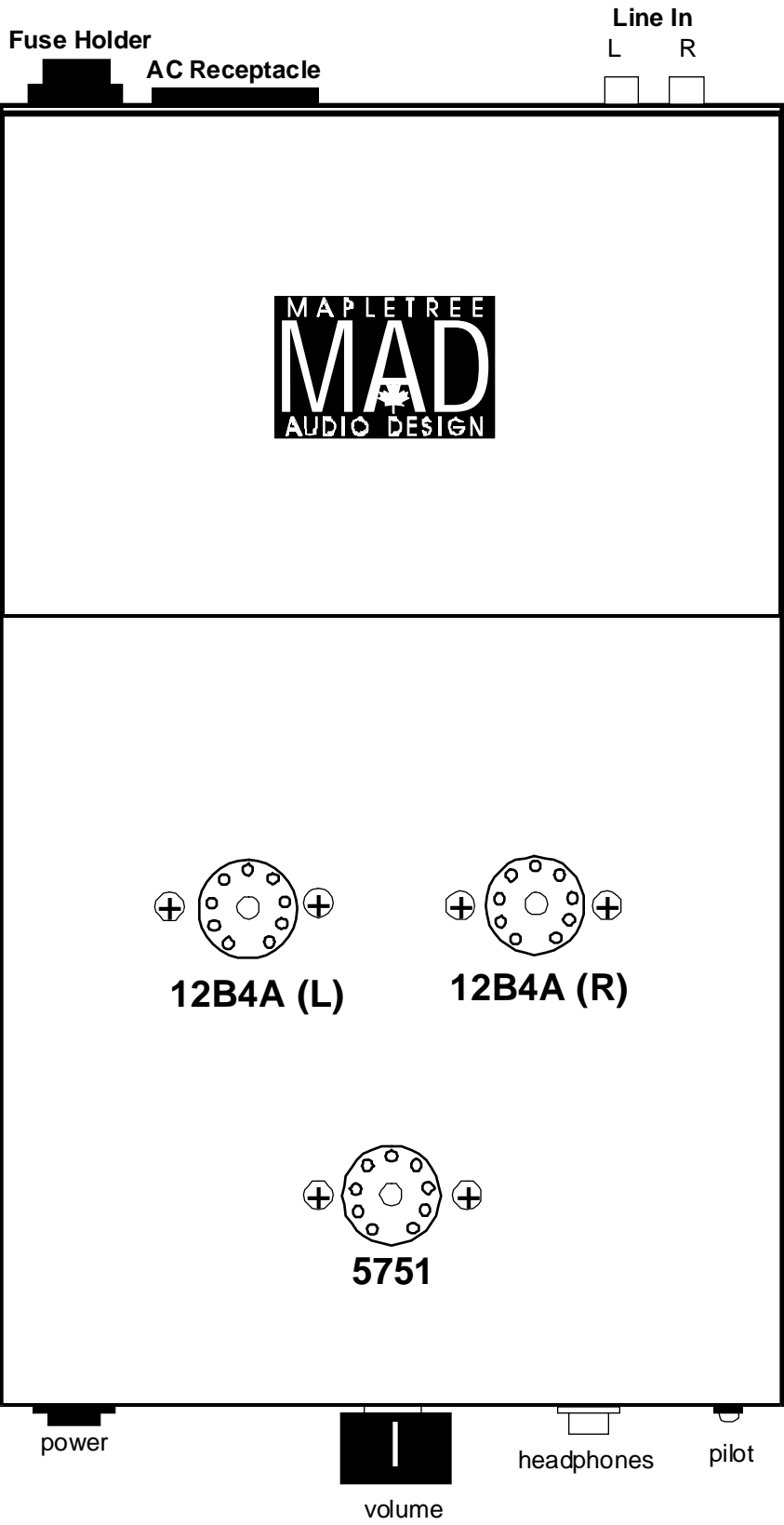

Troubleshooting

- ❑ If the fuse blows when you turn the amplifier on, unplug the line cord and check the ac wiring as above, plus all the dc and heater power supply wiring of phase 2. Look for possible shorts between an exposed wire and the chassis. Don't plug the amplifier in again until you have identified the source of the problem. If you have access to an ohmmeter, check the resistance from lug 1 of T1 to the ground bus. The meter reading should increase to a high value as the filter capacitors charge up. A zero or a few thousand Ohms reading indicates a short circuit somewhere in the dc power supply section—check your wiring from phase 2.
- ❑ If a tube fails to light up (may not be visible in a bright room), check the heater wiring from phase 2. If you have a dc voltmeter, you should read approximately 12 VDC between pins 4 and 5 of each tube.
- ❑ If everything seems normal except you get no sound in one channel, check that the line input/output jacks and the headphones jack are wired correctly (red wires to right channel, green wires to left channel).
- ❑ If you are unable to determine the source of a problem with the simple tests above, contact Mapletree Audio Design by email or telephone before proceeding further. Describe the symptoms of the problem as clearly and completely as possible. A rapid diagnosis should be possible in most cases.

Appendices

Parts List

Resistor Color Codes

Specifications

Schematic Diagram

Circuit Operation

Tube Replacement

Parts List

Reference	Description	Qty.
BR1	3A rectifier bridge	1
C1a,b, C4a,b	1uF/250V polypropylene capacitor	2
C2a,b	47uF/25V electrolytic capacitor	2
C3a,b	33uF/160V electrolytic capacitor	2
C5	47uF/350V electrolytic capacitor	1
C6, C7	47uF/250V electrolytic capacitor	2
C8	4700uF/16V electrolytic capacitor	1
D1-D4	FR107 fast recovery 1A/1000V silicon diodes	4
D5	green LED (pilot light) with holder	1
FU1	0.5 A/250 V 1-1/4" fuse + spare	2
	Fuse holder	1
J1a,b	RCA gold plated phono jack	2
J2	1/4" stereo phones jack	1
J4	IEC ac receptacle	1
	IEC ac line cord	1
P1a,b	100K dual audio potentiometer	1
	Knob	1
R1a,b	330K 0.6W 1% metal film resistor (orange-orange-black-orange)	2
R2a,b	1K 0.6W 1% metal film resistor (brown-black-black-brown)	2
R3a,b	100K 0.6W 1% metal film resistor (brown-black-black-orange)	2
R4a,b	7.5K 3W metal oxide resistor	2
R5	2.7K 5W 5% wire wound resistor	1
R6	4.7K 0.6W 1% metal film resistor (yellow-violet-black-brown)	1
R7	1K 1W 5% carbon film resistor (brown-black-red-gold)	1
R8	1.8 Ohms (1R8) 5% 5W wire-wound resistor	1
SW1	SPST rocker switch	1
TR1	230 V 50 mA power transformer	1
TR2	12.6 V 1 A filament transformer	1
TR3a,b	600:8 Ohm 12W audio output transformer	2
T1-T3	4-lug terminal strip	3
	Spare terminal strip	1
V1a,b	5751 tube	1
V2, V3	12B4A tube	2
	Tube socket-9-pin	3
	Chassis 10x6x2"	1
	Transformer cover chassis 6x4x2"	1
	Chassis bottom plate	1
	Rubber feet	4
	6-32 3/8" machine screw	8
	6-32 hex nuts	8
	4-40 3/8" machine screw	6
	4-40 hex nuts	6
	8-32 1" machine screw	4
	#6 sheet metal screw	6
	red hookup wire	5 ft
	green hookup wire	7 ft
	black hookup wire	6 ft
	Twisted pair of black wires	1
	Copper ground bus wire	1
	Insulation tubing	8 in
	Heat shrink tubing	6 in
	Bare wire	6 in
	60/40 solder	1
	Assembly Manual	1

Resistor Color Codes

Precision Metal Film Resistors 5 or 6-band code

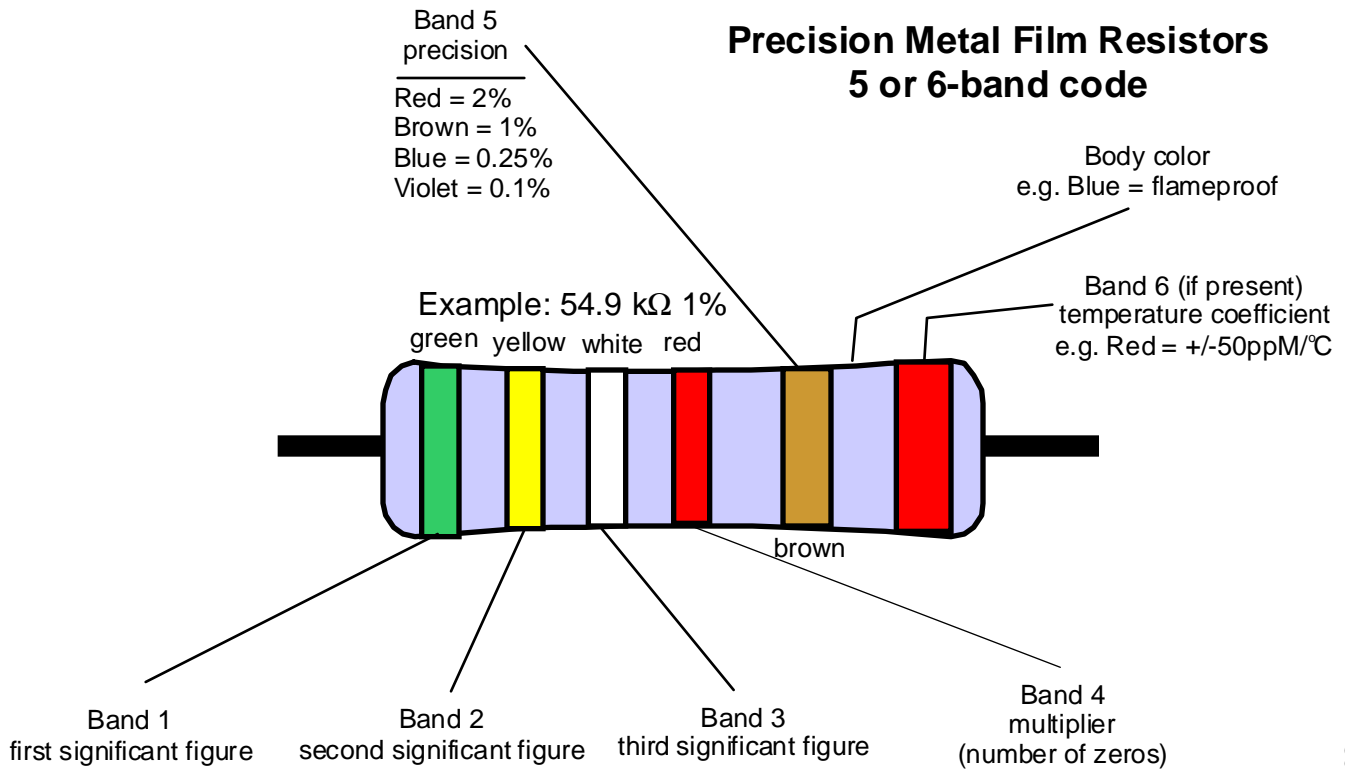

- Black = 0
- Brown = 1
- Red = 2
- Orange = 3
- Yellow = 4
- Green = 5
- Blue = 6
- Violet = 7
- Grey = 8
- White = 9

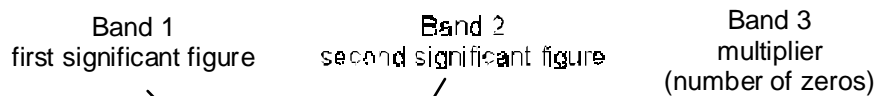

Standard Carbon Film Resistors 4-band code

- Band 4 precision
Gold = 5%
Silver = 10%
None = 20%

MAD Ear+ Purist Specifications

(100 Ω load)

Frequency response at 1 V rms output:

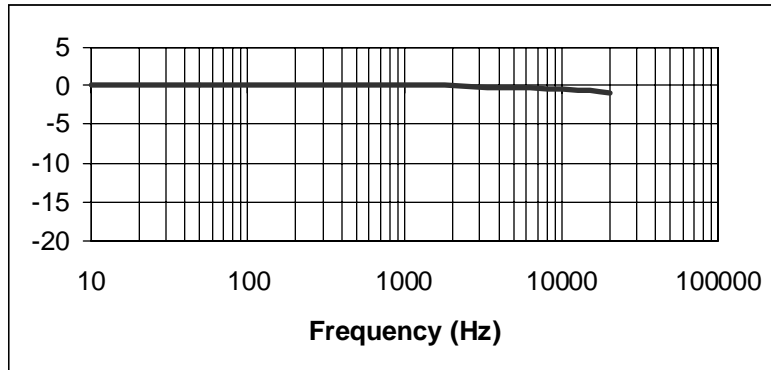

Maximum undistorted output at 1 kHz: 1.5 V rms (70 mW across 32 Ohms)

Sensitivity (for 10 mW output across 100 Ω): 0.4 V

Output impedance at 1 kHz: less than 7 Ω

Input impedance: 90 k Ω

Hum and noise at output (max volume): less than 0.3 mV rms

Minimum load impedance: 32 Ω

Recommended headphone sensitivity: 97 dB/1mW

Phase: non-inverting

Schematic Diagram

MAD Ear+ Headphone Amplifier Purist Version

© Copyright Lloyd Peppard 2003
Rev. July 2/03

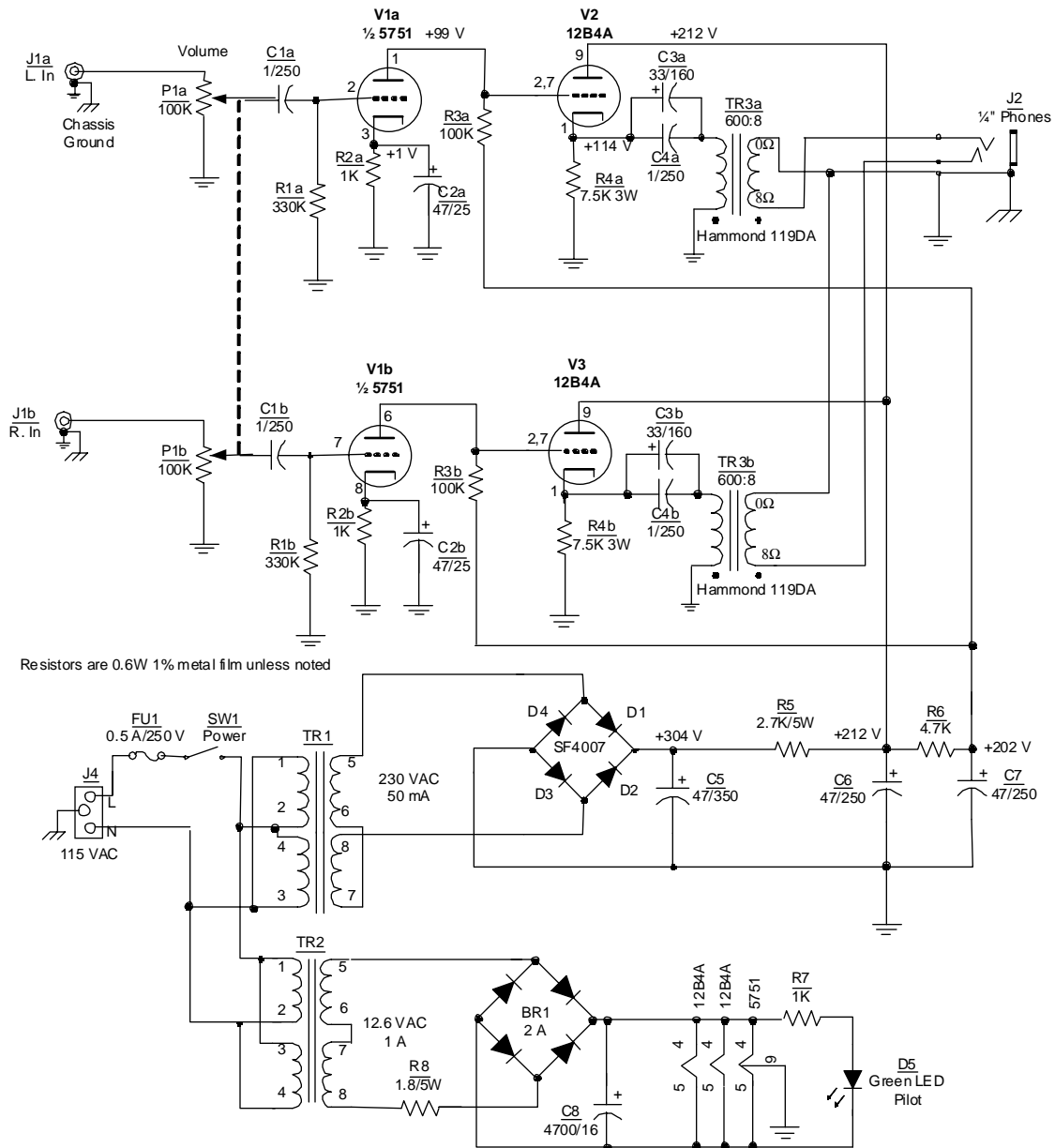

Circuit Operation

Refer to the schematic diagram for the following description of the operation of the *Ear+ Purist*. The left channel (top of the schematic) will be described. The right channel is identical. The line inputs (J1) are coupled to the volume control potentiometer P1 which controls both channels. The wiper of P1a is capacitor coupled to the grid of tube V1a, which is one of the two high mu triodes in the 5751 envelope. This triode is designed as a common-cathode voltage amplifier stage. A self-bias voltage of about -1 V is obtained from resistor R2a with a plate current of 1 mA. The plate resistor R3a sets the plate voltage (plate-to-cathode) to be approximately 98 V. The output signal of this stage (at the plate of V1a) is direct coupled to the grid of the 12B4A tube, V2, which is configured as a cathode-follower driver stage. The grid voltage of the 12B4A is set by the plate voltage of V1a and the grid bias of about -15 V is obtained from the 7.5K cathode load resistor R4a. The plate of V2 is connected directly to the high voltage supply, which provides a plate voltage of approximately 98 V with a plate current of 15 mA.

The cathode-follower stage provides a low output resistance for driving the output transformer. The low internal plate resistance of the 12B4A helps to make the resistance looking back into the cathode quite low (approximately 500 Ohms). This low impedance is the driving point for the primary of the output transformer TR3a. To reduce magnetic saturation of the iron core, para (parallel)-feed is used so only the signal flows through coupling capacitors C3a/C4a and to the primary of TR3a. Polypropylene capacitor C4a in parallel with electrolytic capacitor C3a ensures that the net impedance of this capacitor does not become inductive at high frequencies. The turns ratio of TR3a is approximately 8.7:1, which reduces the output voltage swing available to drive the headphones. However, it also provides an impedance transformation of 75:1, which reduces the driving (output) impedance from 500 to less than 7 Ohms. The secondary of TR3a is directly coupled to the headphones jack J2 with the winding reversed to provide a non-inverting signal path through the amplifier.

The power supply (bottom of the schematic) provides the dc heater voltage and the plate (B+) voltage for the three tubes. The 12 VDC output supplies the heaters of the two 12B4As and the 5751. The use of a dc heater supply ensures the absence of induced hum throughout the signal portion of the circuit. The secondary of transformer TR1 is fed to the full-wave bridge rectifier formed by diodes D1-D4. The output from the bridge filtered by capacitors C5 and C6 together with resistor R5. The dc voltage at C6 feeds the plates of the 12B4As while the plate supply for the input stage is further filtered by resistor R6 and capacitor C7.

Tube Replacement

The tubes supplied with your Ear+ should be good for many thousands of hours of listening. At some point, however, you may find it necessary to replace them. Some users like to experiment with different manufacturer's tubes to obtain subtle differences in audio quality. You may also wish to purchase a spare set for future needs. You can use a 12AX7A, 7025, 5751, or a number of other 12AX7-equivalents for V1.

The following suppliers are three of many sources of NOS tubes of the types required. You may also purchase replacement tubes directly from Mapletree Audio Design.

Pacific T.V.
480 South Joffre St.
Victoria, B.C.
Canada V9A 6C8
Fax: (250) 920-3517 Phone: (250) 386-4283
www.pacifictv.ca

Antique Electronics Supply
6221 South Maple Avenue
Tempe, AZ 85283
Fax: (800) 706-6789 Phone: (480) 829-5411
www.tubesandmore.com

David Boardman Tubes
10 Lemaistre
Sainte-Foy, Québec
Canada G2G 1B4
Phone: (418) 877-1316
www.dbtubes.com