



MapleTree Audio Design  
100 Cliff Cres  
Kingston, ON  
CANADA K7M 1A8

al@mapletreeaudio.com  
www.mapletreeaudio.com

## Notice

**Power supply unit should be plugged into the amplifier unit with the tubes in the correct sockets BEFORE POWERING UP.**

**Please allow at least 12 hours for the tubes to burn in since they are new. It is not uncommon to hear crackling and metal expanding for new tubes.**

**Stacking amplifier on top of the power supply will increased hum. A magnetic shielding plate, 1/8" to 1/4 " "steel plate", with acoustic dampening, felt/rubber, can be used between the amplifier and power supply to reduce the hum. Adding additional pates reduces hum further. If this is still an issue separate the power supply unit from the amplifier unit.**

**Do not clean with alcohol or paint thinner. A soft 1 inch paintbrush is recommended to dust the chassis periodically.**

**Read Manual before operation.**

# Mapletree Audio Design

## *Ultra 4CRM Stereo Phono/Line Preamp* *PS 2D Power Supply*

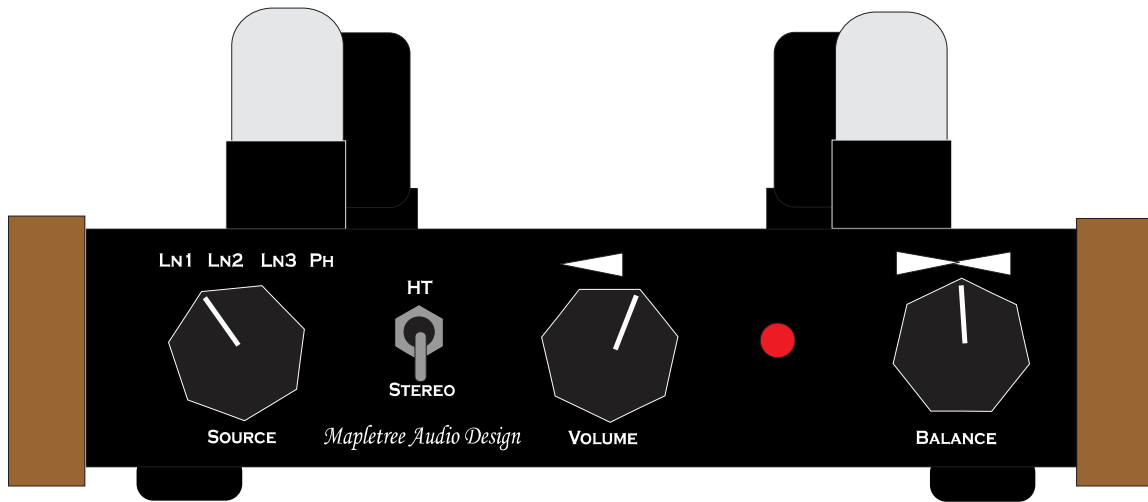

## User's Manual

Rev. Dec. 5, 2023

Mapletree Audio Design  
100 Cliff Cres., Kingston, ON, CANADA, K7M 1A8

[www.mapletreeaudio.com](http://www.mapletreeaudio.com)  
[info@mapletreeaudio.com](mailto:info@mapletreeaudio.com)

## **Introduction**

The Mapletree Audio Design *Ultra 4C Stereo Phono/Line Preamplifier* offers the audiophile a number of desirable features:

- 🔊 Exclusive use of NOS octal tubes, known for low distortion and musicality.
- 🔊 Switchable for use with 12SN7GT or 6SN7GTB tubes.
- 🔊 Precise RIAA equalization ( $\pm 0.5$  dB) using non-interacting passive and active filters.
- 🔊 High input impedance and low output impedance.
- 🔊 Parallel output jacks for bi-amp or headphone amplifier applications.
- 🔊 Home Theater (HT) mode switch on front panel that bypasses the preamp circuitry and connects the selected line input directly to the output jacks.
- 🔊 Enhanced connectivity with 3 line inputs, phono input, and 2 line outputs.
- 🔊 Phono gain of 48 dB suitable for all moving magnet (MM) and high-output moving coil (MC) phono cartridges.
- 🔊 Audio grade polypropylene and polystyrene film capacitors in signal path.

## Power Supply Connections

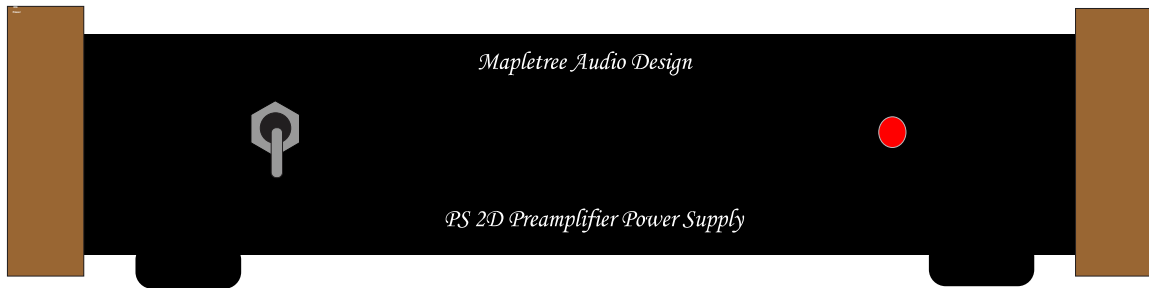

The Mapletree Audio Design *PS 2D* power supply provides +12 VDC (regulated) heater supply voltage and +200 VDC B+ plate supply voltage at a current of 15 mA (see specifications). It utilizes low-noise ultra high-speed diodes to achieve low noise with the high efficiency of the bridge rectifier topology.

The separate power supply eliminates induced hum originating from power supply circuitry and components. The power connections to the preamplifier chassis are made through a special 3-conductor power cord that plugs into jacks located on the rear panels of the power supply and preamplifier chassis.

**CAUTION: Do not operate the power supply when it is not connected to the preamp. Damage of components may result.**



Once the interconnecting power cord is securely attached between the two chassis and the line cord is plugged in, the power supply can be turned on. The pilot lamp on the power supply chassis indicates that the unit is on. It takes about 30 seconds for the tubes to reach operating temperature ready for use. During operation, it is normal for the power supply chassis to become warm to the touch.

The power supply is protected by a 20mm, 1 A/250 V fast-acting fuse, which can be accessed by removing the fuse drawer from the ac inlet receptacle after the unit has been unplugged for at least 60 sec. Under normal conditions, it should not be necessary to replace the fuse. If power fails to come on, you can check the fuse and replace if

necessary. If the fuse blows a second time, you should not try to operate the unit. Contact Mapletree Audio Design for information regarding service.

### Signal I/O Connections\_\_\_\_\_

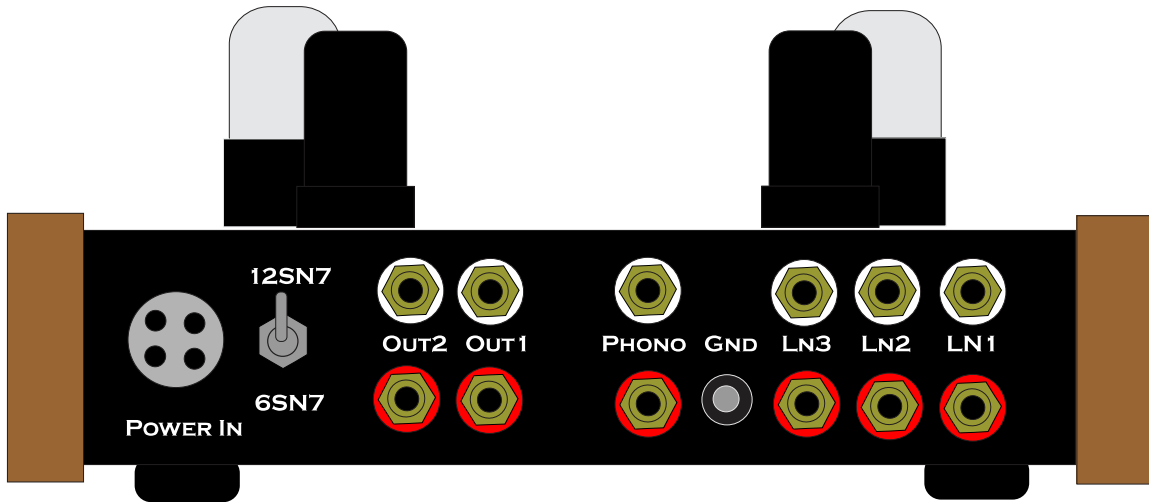

The signal input/output jacks are located on the rear panel of the preamplifier chassis. RCA jacks are provided for phono input, three line inputs, and two line outputs. Left channel jacks are at the top and right channel jacks are at the bottom. A binding post is provided for phono ground. The phono input resistance is 47 k $\Omega$  which matches standard MM phono cartridge loading requirements. The input capacitance is approximately 50 pF. The line input impedance is 440 k $\Omega$  which provides minimal loading of any line source such as CD/DVD player, tape deck, tuner, or PC sound card. The output impedance is less than 500 $\Omega$  which is suitable for connection to a power amplifier through cables up to 10 ft in length. The ground wire from the turntable should be connected to the ground binding post to minimize hum pickup.

In HT mode (see below), the selected line input is connected directly to the output jacks and the preamp can be powered off.

The heater voltage switch located next to the power input jack allows you to accommodate either 12SN7GT (supplied) or 6SN7GTB tubes in your *Ultra 4C*. Note that the switch does not affect the heater voltage for the 12SC7 tubes. ***While it will do no damage to switch to 6SN7 position with 12SN7 tubes installed, operation in the 12SN7 position with 6SN7 tubes may damage the tubes.***

## **Front Panel Controls**

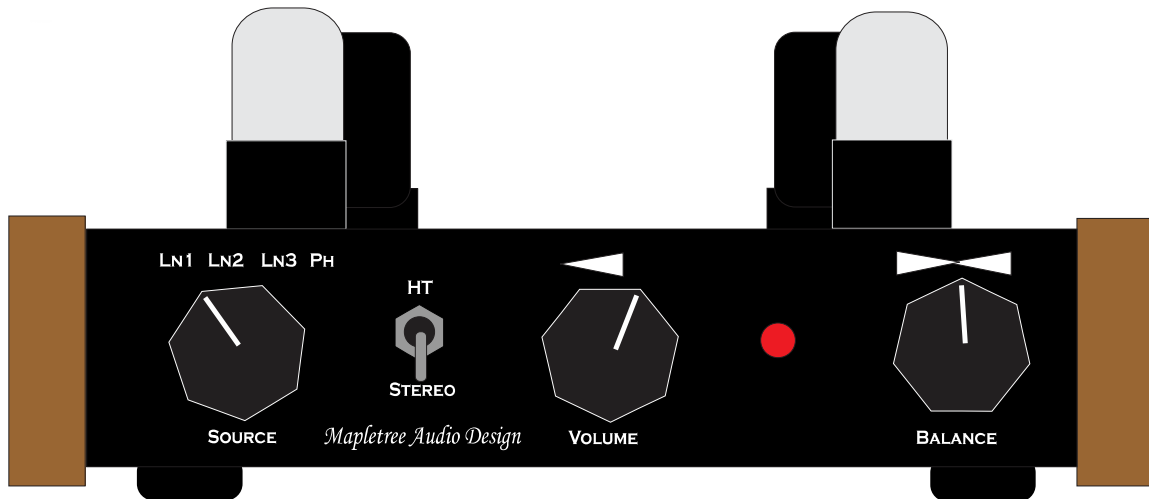

The front panel controls are (left to right) the 4-position Source selector switch (Line1-Line2-Line3-Phono), mode switch (Stereo or Home Theater), Volume control , and Balance control. In HT mode, the selected line input is connected directly to the output jacks on the rear panel. The preamp circuit is no longer connected to the output jacks so the power supply can be turned off.

## **Remote Volume Control**



The volume control IR sensor is located between the volume and balance control as shown above. The remote handset has buttons for volume up and down. The “OFF/ON” button mutes the preamp.

## **Tubes**

The preamp vacuum tube socket locations are shown in the following diagram. The 12SC7s are toward the rear of the chassis. The tubes supplied are new-old stock (NOS) and have been pre-tested. A burn-in period of several hours may be needed to achieve the best sonic performance. Tube life should be thousands of hours. Aging tubes may result in a reduced gain in one or both channels or an increase in noise levels. Infrequently, a heater may burn out which is indicated by total loss of sound. Replacement tubes can be obtained from several suppliers in the U. S. and Canada. Mapletree Audio Design will attempt to provide replacement tubes to customers at cost plus shipping. Some listeners enjoy trying different brands and variants of tubes. The heater voltage selector switch permits the use of NOS 6SN7GTB tubes (see below). The highly regarded 12SX7GT is equivalent to the 12SN7GT.

**Note:** With the heater voltage switch in the 6SN7 position, the two tube heaters are connected in series. Many old stock 6SN7 tubes (e.g. 6SN7GT/GTA) may not have well matched heater characteristics, which means that the two tubes may not share the 12 VDC evenly, which is not desirable. The 6SN7GTB was developed expressly for series heater connections in early TVs so should work fine in the preamp. Some old and currently manufactured 6SN7 tubes may work well in the series configuration but this should be verified by measuring the voltage across each tube heater (pins 7-8).

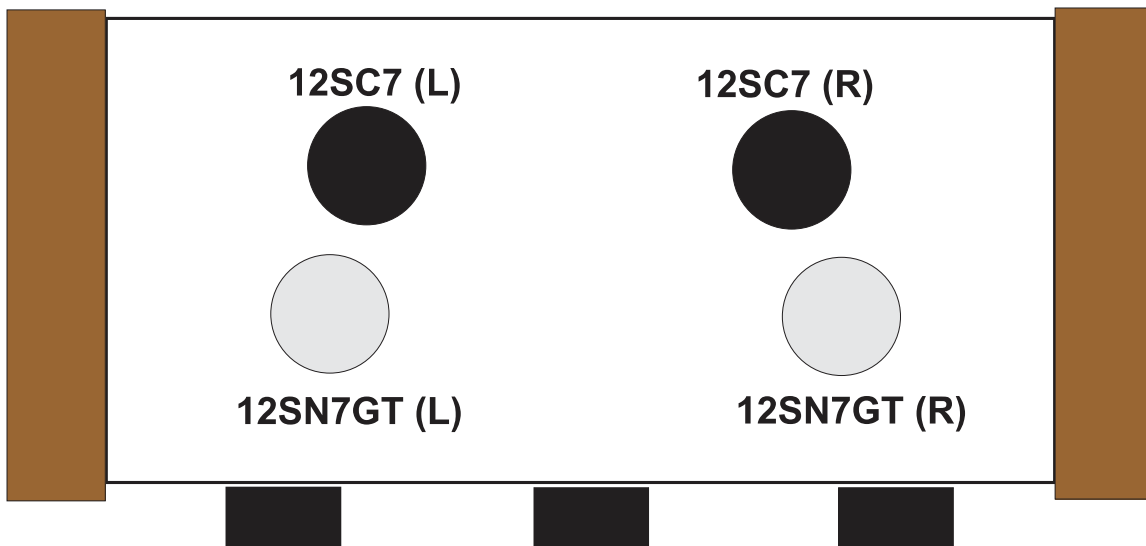

### **Care of your Ultra 4**

The chassis finish is lacquer-based. Both the chassis and labels/logos are moisture resistant but you should avoid cleaning with water, alcohol, or other strong chemical. A soft 1" paintbrush is recommended to dust the chassis periodically.

Heat is the most troublesome enemy of electronic components, especially capacitors. Heat can be properly dissipated by ensuring free air circulation around the preamp and power supply chassis. It is not recommended that you leave the power on when not in use.

### **Warranty**

Assembled components are warranted for 2 years to the original purchaser for failure of parts (excluding tubes) and workmanship. Tubes are warranted for 90 days exclusive of shipping cost. Service, including parts and labor (but excluding shipping), is free within the warranty period.

## **Mapletree Audio Design Ultra 4C Specifications**

### **Phono Section (100 k $\Omega$ load)**

**Max. RIAA error:** 0.5 dB 30–20 kHz

**Maximum Gain:** 50 dB (1 kHz)

**Noise:** less than 1 mV for gain of 40 dB

**Input resistance at 1 kHz:** 47 k $\Omega$

### **Line Section (100 k $\Omega$ load)**

**Frequency response (1 V output, 100K load):** 20 Hz–20 kHz –0.5 dB (any volume control setting)

**Max. output voltage (100K load):** 15 V rms

**Gain:** 14 dB

**Channel balance:**  $\pm 0.5$  dB

**Balance control:** 3 dB channel shift at 9 and 3 o'clock with vol. control at 12 o'clock

**Hum and noise:** less than 150  $\mu$ V at 10 dB gain

**Input impedance (1 kHz):** 440 k $\Omega$

**Output impedance (1 kHz):** 450  $\Omega$

### **Power Supply (PS 2D)**

**Power input:** 120 VAC, 50-60 Hz (can be wired for 240 VAC)

**Power output:** +12 VDC @ 1A, +180-250 VDC @ 14 mA (ground is common to both).

**Fuse:** 1 A, 250 V fast action 20 mm fuse

**Power consumption:** 30 W



# Mapletree Audio Design Ultra 4C Phono/Line Preamplifier

Rev. Mar 22/19  
Design and specifications subject to change without notice

© Copyright Lloyd Peppard 2002-2019

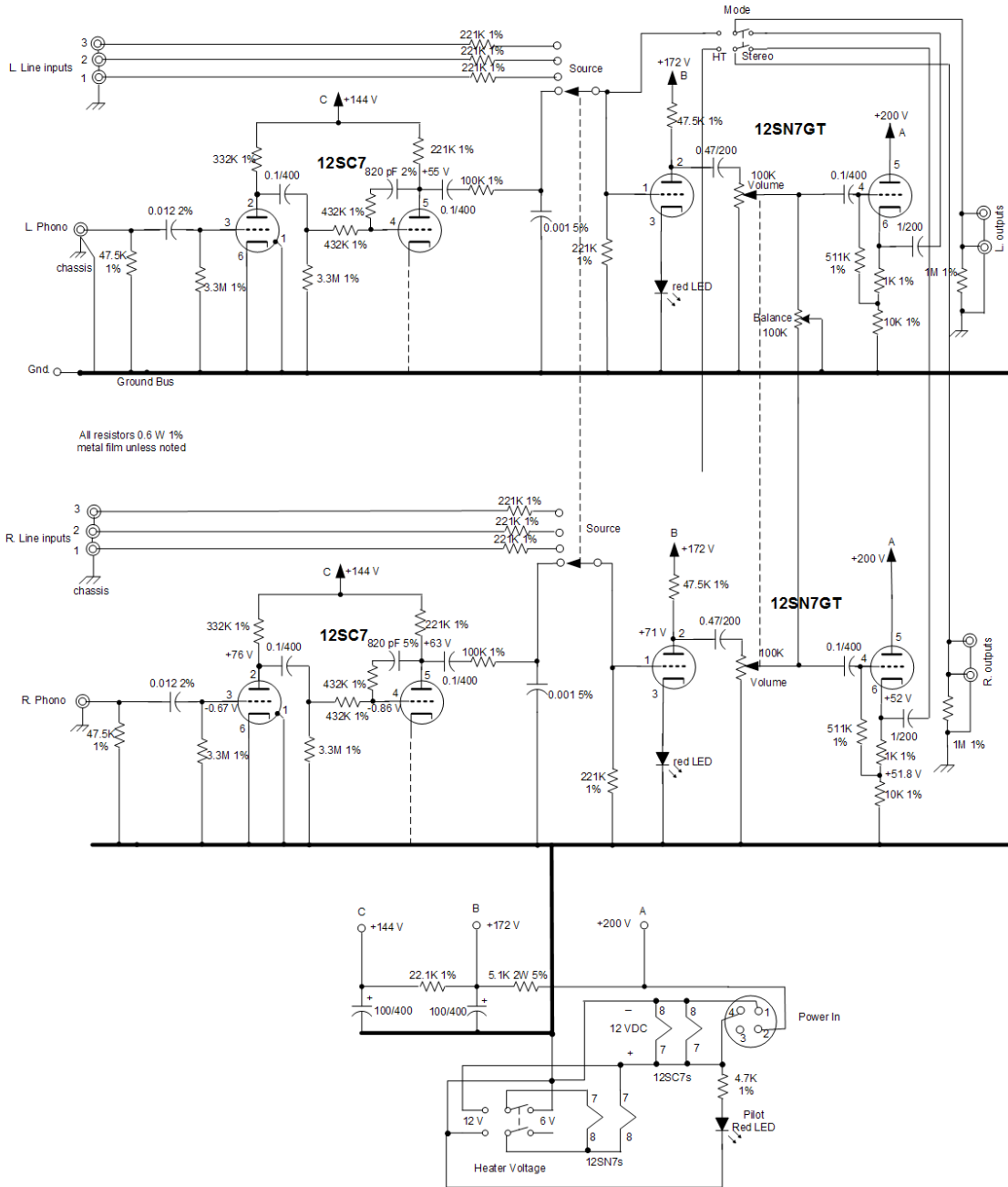

# Mapletree Audio Design Preampifier Power Supply PS 2D for Preamps Ultra 4C/4CRM, Line 2C/2CRM

© Copyright Lloyd Peppard 2018

Rev. June 3/18

