

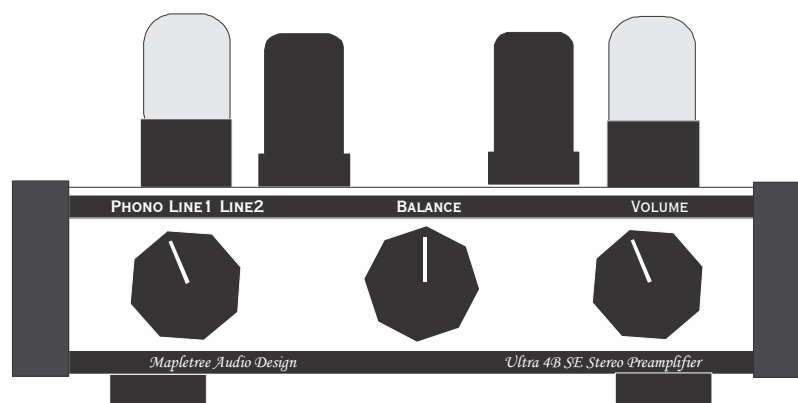

Ultra 4B SE Special Edition
Stereo Phono/Line Preamp

User's Manual



Rev. Feb. 22/13

Mapletree Audio Design
Lloyd Peppard
R. R. 1, Seeley's Bay, Ontario, Canada, K0H 2N0
(613) 387-3830
www.mapletreeaudio.com
info@mapletreeaudio.com

© Copyright Lloyd Peppard 2002-2013
-Specifications are subject to change without notice-

Introduction

The Mapletree Audio Design *Ultra 4B SE Stereo Phono/Line Preamplifier* offers the audiophile a number of desirable features:

- ? ? Compact chassis layout for use with separate power supply for low noise.
- ? ? Exclusive use of NOS octal tubes, known for low distortion and musicality.
- ? ? Switchable for use with 12SN7GT or 6SN7GT tubes.
- ? ? Precise RIAA equalization (± 0.5 dB) using non-interacting passive and active filters.
- ? ? High input impedance and low output impedance.
- ? ? Parallel output jacks for bi-amp or headphone amplifier applications.
- ? ? Phono gain of 48 dB suitable for all moving magnet (MM) and high-output moving coil (MC) phono cartridges.
- ? ? Audio grade polypropylene and polystyrene film capacitors in signal path.

Power Supply Connections

The Mapletree Audio Design *PS 2* power supply provides +12 VDC (regulated) heater supply voltage and +200 VDC B+ plate supply voltage at a current of 15 mA (see specifications). It utilizes a slow start cathode type rectifier tube (6X5GT) in conjunction with low-noise ultra high-speed diodes to achieve all the advantages of tube rectification (low noise, soft startup) with the high efficiency of a bridge rectifier topology. The separate power supply eliminates induced hum originating from power supply circuitry and components. The power connections to the preamplifier chassis are made through a special 3-conductor power cord that plugs into jacks located on the rear panels of the power supply and preamplifier chassis.

CAUTION: Do not operate the power supply when it is not connected to the preamp. Damage of components may result.

Once the interconnecting power cord is securely attached between the two chassis and the line cord is plugged in, the power supply can be turned on. The pilot lamp on the power supply chassis indicates that the unit is on. It takes about 30 seconds for the tubes to reach

operating temperature ready for use. During operation, is it normal for the power supply chassis to become warm to the touch.

The power supply is protected by a 1 A/250 V fast-acting fuse, which can be accessed by removing the bottom chassis cover after the unit has been unplugged for at least 60 sec. Under normal conditions, it should not be necessary to replace the fuse. If power fails to come on, you can check the fuse and replace with a spare if necessary. If the fuse blows a second time, you should not try to operate the unit. Contact Mapletree Audio Design for information regarding service.

Signal I/O Connections

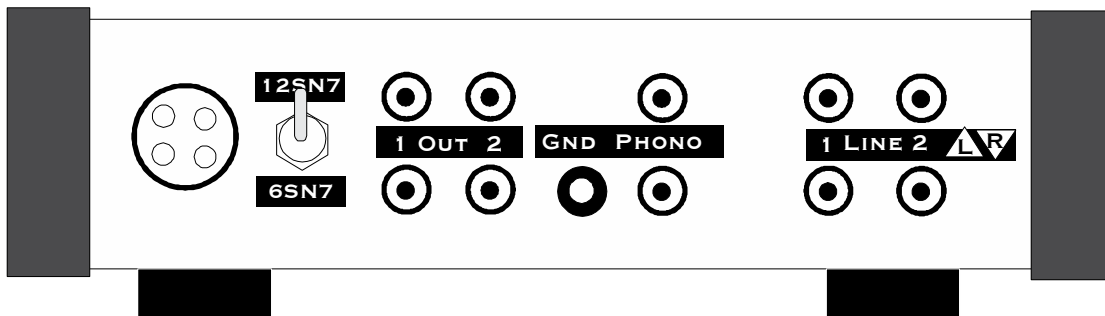

The signal input/output jacks are located on the rear panel of the preamplifier chassis. RCA jacks are provided for phono input, two line inputs, and two line outputs. Left channel jacks are at the top and right channel jacks are at the bottom. A binding post is provided for phono ground. The phono input resistance is 47 k Ω which matches standard MM phono cartridge loading requirements. The input capacitance is approximately 50 pF. The line input impedance is 470 k Ω which provides minimal loading of any line source such as CD/DVD player, tape deck, tuner, or PC sound card. The line output impedance is less than 500 Ω which is suitable for connection to a power amplifier through cables up to 10 ft in length. The ground wire from the turntable should be connected to the ground binding post to minimize hum pickup.

The heater voltage switch located next to the power input jack allows you to accommodate either 12SN7GT (supplied) or 6SN7GT tubes in your *Ultra 4A*. Note that the switch does not affect the heater voltage for the 12SC7 tubes. ***While it will do no damage to switch to 6SN7 position with 12SN7 tubes installed, operation in the 12SN7 position with 6SN7 tubes may damage the tubes.***

Front Panel Controls

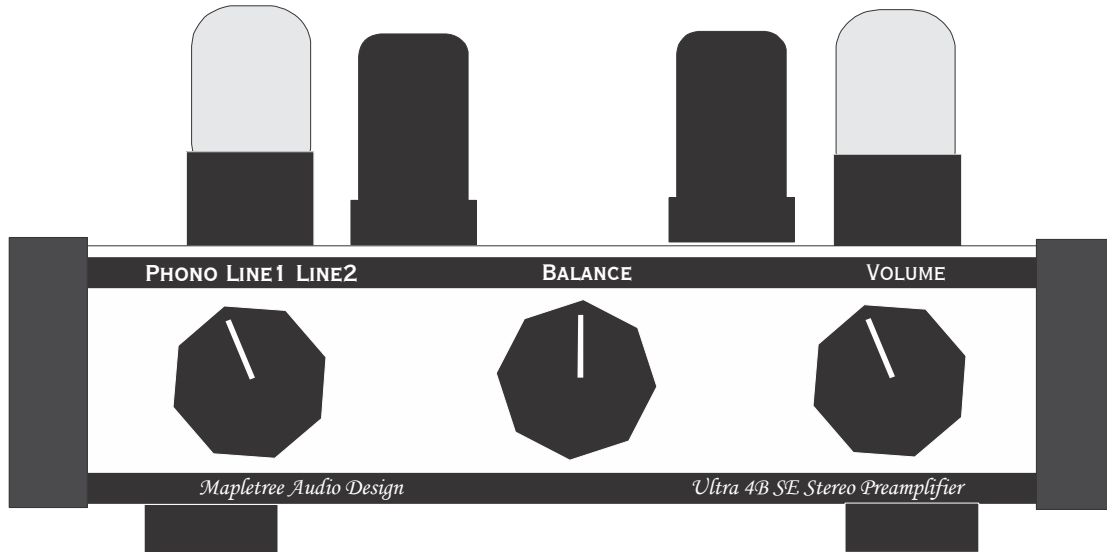

The front panel controls are (left to right) the 3-position Source selector switch (Phono-Line1-Line2), the Balance control, and the Volume control, which adjusts the gain of both channels simultaneously. *If you find that you hear pops from your speakers when switching between sources, turn down the volume control before switching.*

Tubes

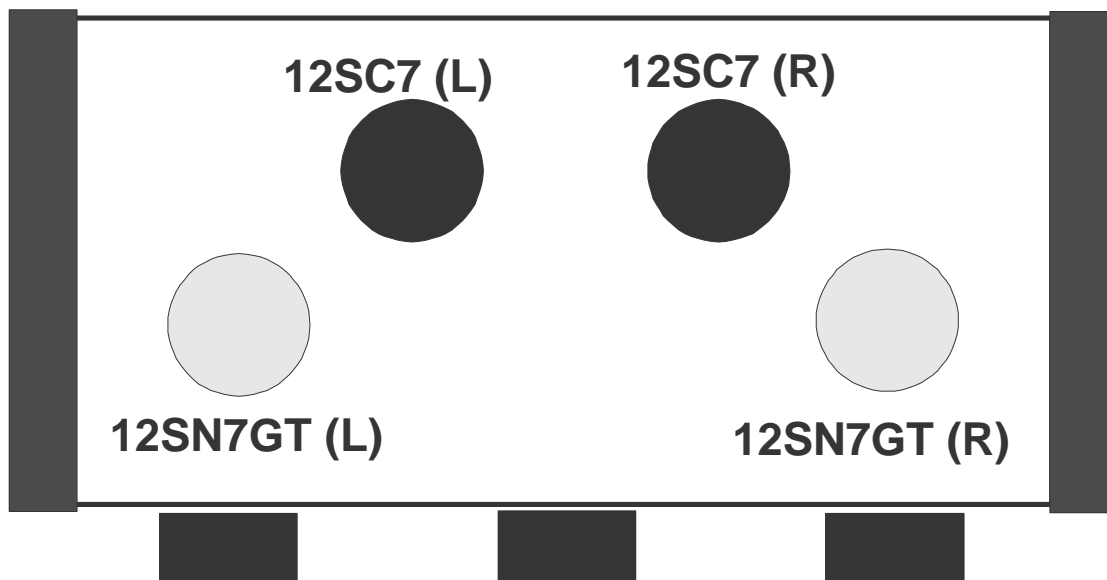

Vacuum tube socket locations are shown in the diagram on p. 6. The 12SC7s are toward the rear of the chassis. The tubes supplied are new-old stock (NOS) and have been pre-tested. A burn-in period of several hours may be needed to achieve the best sonic performance. Tube life should be thousands of hours. Aging tubes may result in a reduced gain in one or both channels or an increase in noise levels. Infrequently, a heater may burn out which is indicated by total loss of sound. Replacement tubes can be obtained from several suppliers in the U. S. and Canada. Mapletree Audio Design will attempt to provide replacement tubes to customers at cost plus shipping. Some listeners enjoy trying different brands and variants of tubes. The heater voltage selector switch permits the use of 6SN7GT (or the 5692 special red version) tubes of NOS or current manufacture. The highly regarded 12SX7GT is equivalent to the 12SN7GT.

Warranty

Assembled components are warranted for 2 years to the original purchaser for failure of parts (excluding tubes) and workmanship. Tubes are warranted for 90 days exclusive of shipping cost. Service, including parts and labor (but excluding shipping), is free within the warranty period.

MAD Ultra 4B SE Phono/Line Preamp

© Copyright Lloyd Peppard 2002-2013
Rev. Jan. 21/13

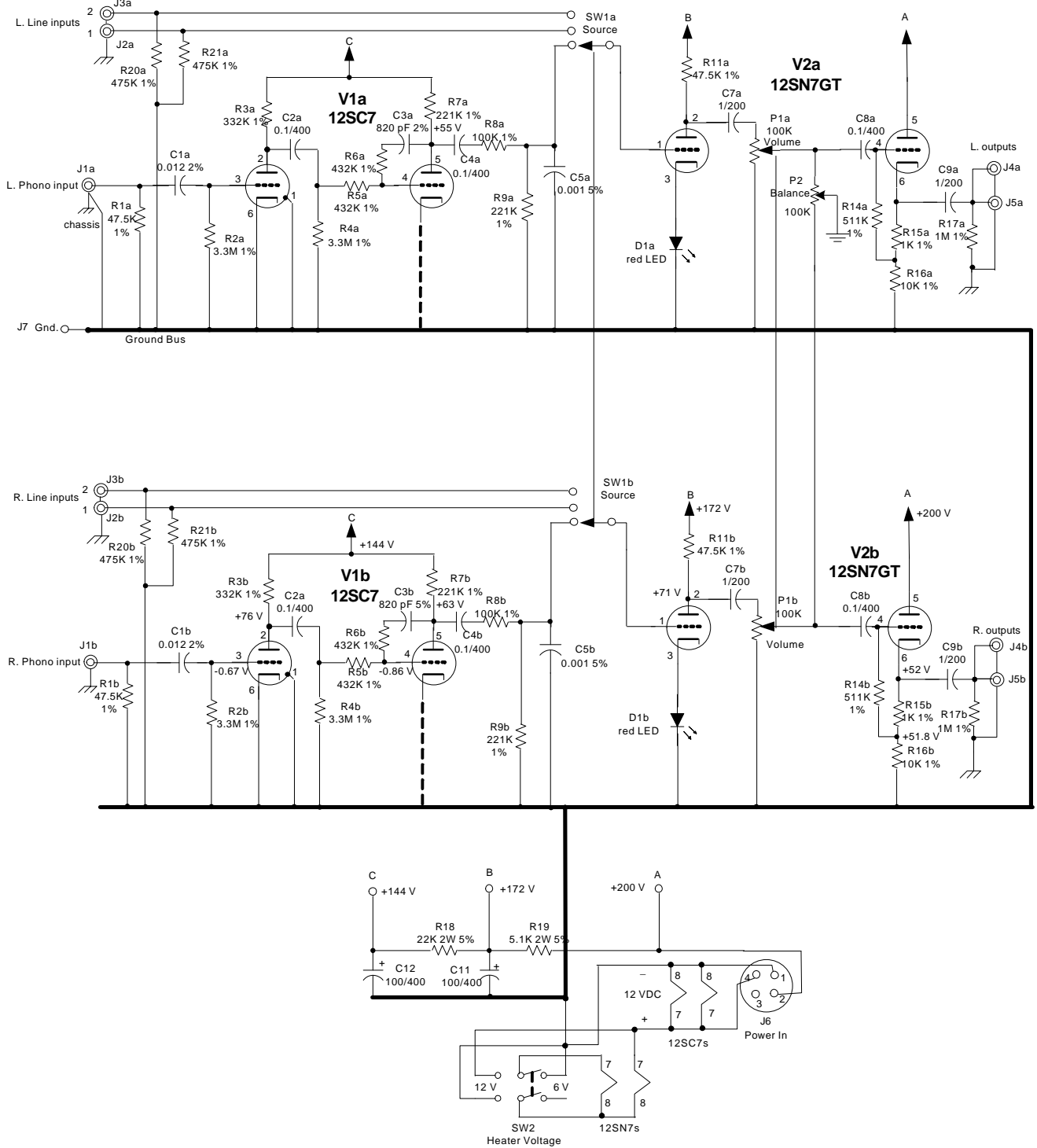

Parts List

Reference No.	Description
C1a,b	0.012uF/160V 2% polystyrene capacitor
C2a,b, C4a,b, C8a,b	0.1uF/400 V polypropylene film capacitor
C3a,b	820pF/630V 2.5% polystyrene capacitor
C5a,b	0.001uF/100 V 5% polypropylene capacitor
C7a,b, C9a,b	1uF/200 V polypropylene film capacitor
C11a,b, C12a,b	100uF/400V electrolytic capacitor
D1a,b	10 mA red LED
J1a,b–J5a,b	RCA gold plated phono jack
J6	4-pin chassis jack (power in)
J7	Ground binding post
P1a,b	100K dual audio taper potentiometer
P2a,b	100K linear potentiometer
R1a,b, R11a,b	47.5K 0.5W 1% metal film resistor
R2a,b, R4a,b	3.3M 1W 10% carbon film resistor
R3a,b	332K 0.6W 1% metal film resistor
R7a,b, R9a,b	221K 0.6W 1% metal film resistor
R5a,b, R6a,b	432K 0.6W 1% metal film resistor
R8a,b	100K 0.5W 1% metal film resistor
R14a,b	511K 0.6W 1% metal film resistor
R15a,b	1K 0.6W 1% metal film resistor
R16a,b	10K 0.6W 1% metal film resistor
R17a,b	1M 0.5W 1% metal film resistor
R18	22K 2W 5% metal oxide resistor
R19	5.1K 2W 5% metal oxide resistor
R20a,b, R21a,b	475K 0.6W 1% metal film resistor
SW1	3 position, 4-pole rotary switch (2 poles used)
SW2	DPDT heater voltage selector switch
V1a,b	12SC7 tube
V2a,b	12SN7GT tube

Circuit Operation

Referring to the schematic diagram, both channels are identical. The following description refers to either channel unless otherwise noted. The phono input signal is applied to input jack J1, loaded by resistor R1, then capacitor coupled to the grid of the first section of the 12SC7 which is configured as a common-cathode voltage amplifier. Capacitor C1 sets the low frequency breakpoint in the RIAA equalization curve at 50 Hz. The negative grid bias is obtained through the grid resistor R2. The output from this stage is capacitor coupled through C2 to the second stage which uses the second section of the 12SC7 also configured as a common-cathode voltage amplifier. The feedback network consisting of R5, R6, and C3 implements the turnover frequency of the RIAA curve at 500 Hz. Bias is again obtained through the leakage grid current flowing through the 3.3 M Ω resistor R4.

The signal is then capacitor coupled through C4 to the phono terminal of the source selector switch (SW1). The passive network comprised of R8 and C5 implements the roll-off frequency of the RIAA curve at 2130 Hz. The selector switch is used to steer either the amplified phono signal or one of two line input signals (jacks J2 and J3) to the third stage, which utilizes the first section of the 12SN7GT in a common-cathode voltage amplifier configuration giving a gain of around 22 dB. This stage is biased by a light-emitting diode (LED) which provides the required dc bias voltage while presenting a low resistance to signals. This eliminates the necessity of an electrolytic cathode resistor bypass capacitor. The output of this stage is capacitor coupled through C7 to the volume control potentiometer P1 and to the balance control potentiometer P2. The wiper of the level control is capacitor coupled through C8 to the grid of the output stage, which employs the second section of the 12SN7GT configured as a cathode-follower. This stage has a voltage gain of less than unity but provides a low output impedance suitable for driving cable capacitance without loss of high frequencies. Grid bias is obtained by resistors R14 and R15 while R16 establishes the plate voltage and current to provide maximum output voltage swing. The output voltage is taken from the cathode of the output stage, capacitor coupled to the output jacks J4 and J5 through capacitor C9.

MAD Ultra 4B Specifications

Phono Section (100 k Ω load)

Max. RIAA error: 0.5 dB 30–20 kHz

Maximum Gain: 50 dB

Noise: less than 3mV for gain of 48 dB; less than 1 mV for gain of 40 dB

Input resistance at 1 kHz: 47 k Ω ?

Line Section (100 k Ω load)

Frequency response (1 V output, 100K load): 20 Hz–20 kHz –0.5 dB (any volume control setting)

Max. output voltage (100K load): 15 V rms

Gain: 18 dB

Channel balance: ± 0.5 dB

Hum and noise: less than 150 μ V at full gain, input shorted

Input impedance (1 kHz): 475 k Ω ?

Output impedance (1 kHz): 450 Ω ? ?
?

Power requirements: +12 VDC @ 1A, +180-250 VDC @ 14 mA (ground is common to both supplies)

Power Supply Parts List

Reference No.	Description
BR1	6A/200V diode bridge
C1a,b	Dual 50uF-50uF/500V electrolytic capacitor
C2	10000uF/16V electrolytic capacitor
D1	1N4007 diode
D2	10 mA LED
D3, D4	MUR180 high speed diode (800 V)
FU1	½ A/250 V fast action fuse
J1	4-pin chassis jack
J2	IEC ac line receptacle
IC1, IC2	7812 voltage regulator
R1	6.8K 5W 5% wire-wound resistor
R2	220K 1W 5% metal film resistor
R3	1.8K 1W 5% carbon film resistor
SW1	SPST power switch (250 V rated)
TR1	230 VAC/25 mA power transformer
TR2	14 VAC/1.4 A filament transformer
TR3	6.3 VAC/0.9 A filament transformer
V1	6X5GT rectifier tube

Mapletree Audio Design Preamplifier Power Supply PS 2

© Copyright Lloyd Peppard 2003-13

Rev. Feb. 17/13

